

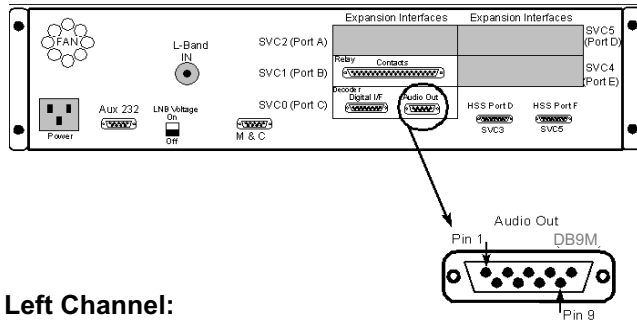

Legacy System StarGuide wiring (For reference purposes) Talk and Sports



Left Channel:

Pin 1 (+)
Pin 6 (-)
Pin 2 Ground } Audio for Ch 42 or 09-0

Right Channel

Pin 5 (+)
Pin 9 (-)
Pin 4 Ground } Audio for Ch 44 or 09-1

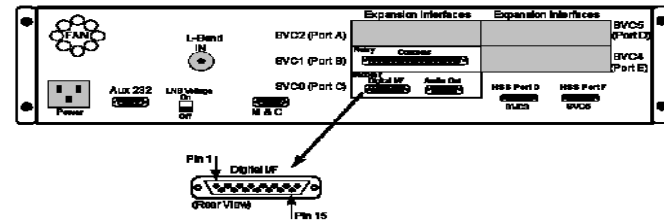

PIN 2 Relay 1 NO	} Local Avail	Ch 42 09-0
PIN 10 Relay 1 Comon		
PIN 3 Relay 2 NO	} ID	Ch 42 09-0
PIN 11 Relay 2 Com		
PIN 4 Relay 3 NO	} Local Avail	Ch 44 09-1
PIN 12 Relay 3 Com		
PIN 5 Relay 4 NO	} ID	Ch 44 09-1
PIN 13 Relay 4 Com		
PIN 9 RS232 Transmit		
PIN 1 RS232 Receive		
PIN 6 RS232 Ground		

Using a talk show or sporting event as an example:

The Left audio channel (Ch 42 for Sports or 09-0 for Talk) would provide the audio content of that program. Relays 1 (Local Avail) and 2 (station ID) would be associated with the left channel.

The Right audio channel (Ch 44 for Sports or 09-1 for Talk) would provide the audio content of that program. Relays 3 (Local Avail) and 4 (station ID) would be associated with the right channel .

* With the New MAX receiver, we'll no longer be splitting programs into left and right channels like above and the relays will be the same all the time. You'll always get the same program from both left and right, or stereo if the program is transmitted that way. See the new MAX wiring diagrams for details.